



Dedicated to service. Driven by quality.



IGNITION | FILTERS | BRAKES | LIGHTING



TURN IT ON

CHAMPION SPARK PLUGS

PART I - HOW DOES A SPARK PLUG WORK?



A CHAMPION SPARK PLUG IN DETAIL

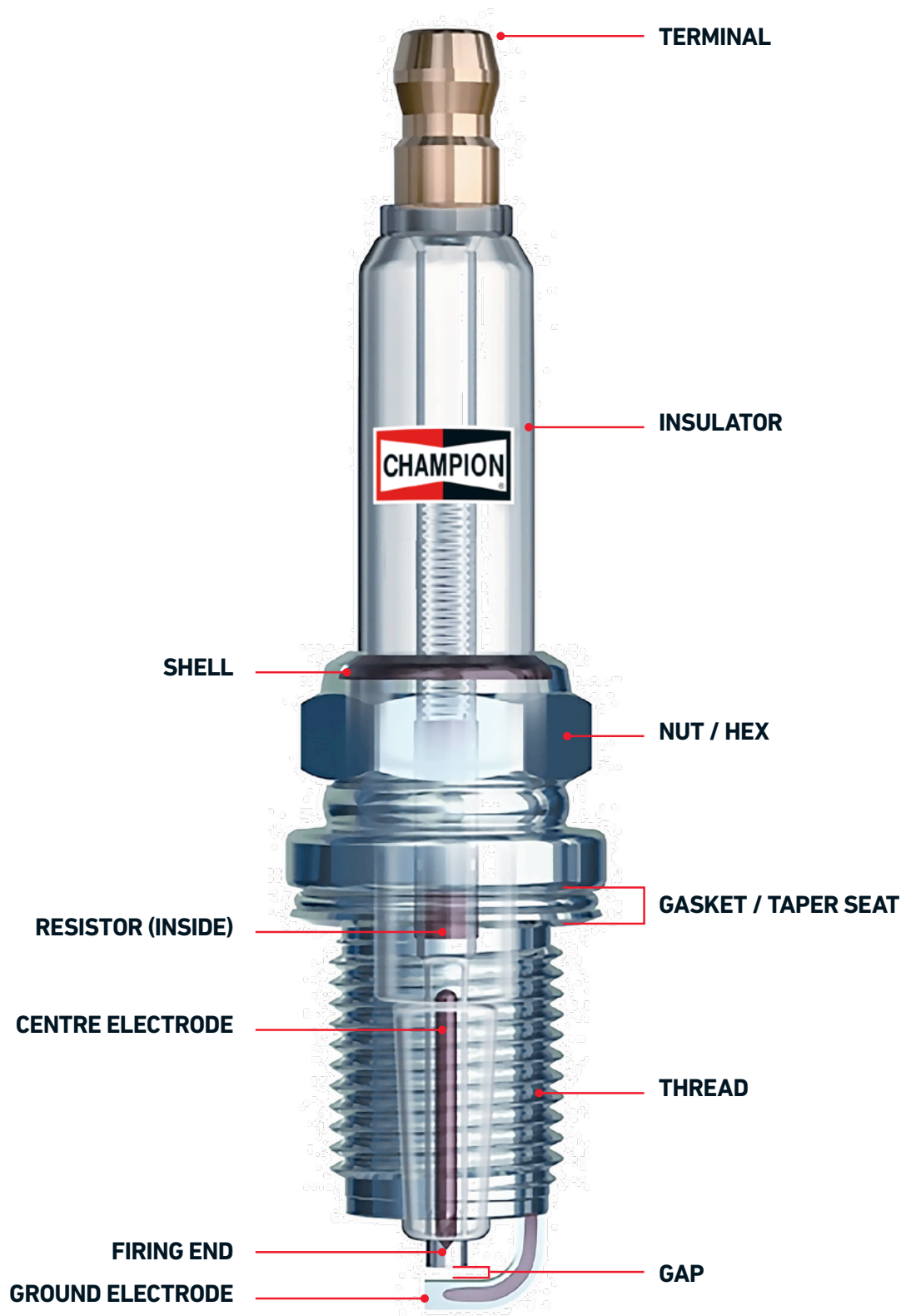

IF IT HAS AN ENGINE, WE HAVE A PLUG FOR IT

We permanently want to serve you better and support your business. How? By offering you first-class products and a complete range in combination with **all the information you need**. That's why we created **3 brochures** for you:

Part 1. How does a spark plug work?

In the first brochure, we **guide you through the components** that are used in Champion spark plugs and determine the performance and durability of the spark plug. But did you know that the most essential information is already at your fingertips? As you will read in our second brochure.

Part 2. Our part number structure explained

Every Champion spark plug product number holds detailed specifications about its different components (e.g. resistor, shell, seat), the used technology (e.g. Copper) and its features (e.g. Ribbed Core Nose). An overview of all possible combinations is available in our paper and online catalogue. We'll give you a more detailed explanation.

Part 3. The technologies inside Champion spark plugs

Finally, in our last brochure, we **guide you through the technologies** that are used in Champion spark plugs.



Original OE-quality

When you are the world's number one spark plug provider, customers turn to you with all kinds of questions. OEMs push us to come up with new technologies and solutions that fit the needs of their latest ignition developments. As these spark plug technologies innovations are quick to be released into the aftermarket, we ensure and inform distributors and installers at the same speed.

Let's get started: just turn the page to learn more about Champion spark plugs!

WHAT DOES A SPARK PLUG DO?

Diesel-driven engines have glow plugs, petrol-driven engines have spark plugs.

The ignition system on petrol-driven engines is external: during the compression cycle the combustion of the compressed fuel-air mixture is triggered by an electrical spark produced by the spark plug.

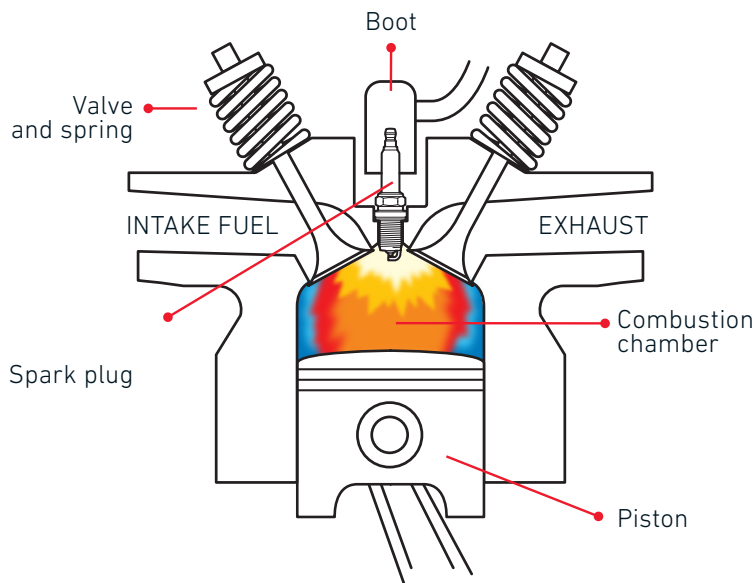

Petrol-driven engines have an external ignition system: a spark plug conducts the spark to the combustion chamber where it initiates the combustion.

The spark plug generates this spark

Created by the high voltage produced by the ignition coil, it leaps between the electrodes. A flame front spreads from the spark and fills the combustion chamber until the mixture has been burned. The heat released increases the temperature, there is a rapid buildup of pressure in the cylinder and the piston is forced downwards. The movement is transferred via the connecting rod to the crankshaft; this drives the vehicle via the clutch, the gears and the axles.

Spark plug requirements

In order for the engine to operate smoothly, powerfully and in an environmentally friendly manner the correct amount of perfectly balanced fuel/air mixture must be present in the cylinder, and the high-energy ignition spark must leap between the electrodes precisely at the predetermined moment.

For this purpose spark plugs have to meet the highest performance requirements: they must deliver a powerful ignition spark during hours of driving at high revs or in stop-and-go traffic conditions. Even at $-20\text{ }^{\circ}\text{C}$, they have to ensure a completely reliable ignition. High-tech spark plugs provide low-emission combustion and optimum fuel efficiency.

Champion spark plugs are designed and manufactured using high quality materials to consistently meet these extreme requirements. Even at the engine development stage, Champion engineers work closely with the motor industry to ensure that the spark plugs are precisely adapted to specific conditions in the combustion chamber.

Champion offers a wide range of spark plugs to ensure that the optimum spark plug is always available for the many different engine types and applications. Diverse materials are used for the center and ground electrodes. This is the technology of the spark plug.



Each spark plug delivers non-stop sparks between around 500 and 3500 times a minute.

EVERY CHAMPION SPARK PLUG IS COMPOSED OF FIVE MAIN COMPONENTS

1. In today's plugs, a **resistor** is built in to eliminate radio frequency interference.
2. The **shell** is a threaded metal hex (made from extruded steel) that seals the combustion and makes it possible to install or remove the plug.
3. Each spark plug has its particular **heat range**. The insulator prevents secondary ignition voltage grounding anywhere else — other than the gap — and it moves the heat from the combustion process to the cylinder head (and into the cooling system).
4. The ground and centre **electrodes** position the spark in the ignition chamber.
5. The **gap** is the distance between the centre and the ground electrode. This is what the ignition spark must jump across. Finally, the **terminal** connects the plug to the ignition system.

Why this is important to you and your customers?

The performance and durability of a spark plug is determined by the characteristics of each of its parts. In order to help you **choose the right plug and support your customers**, we use our part numbers. Champion uses a part numbering system that gives you **useful information on the different components and the characteristics** of each spark plug.

In brochure part II, we'll explain to you what's behind our part numbering system.

3. Heat range

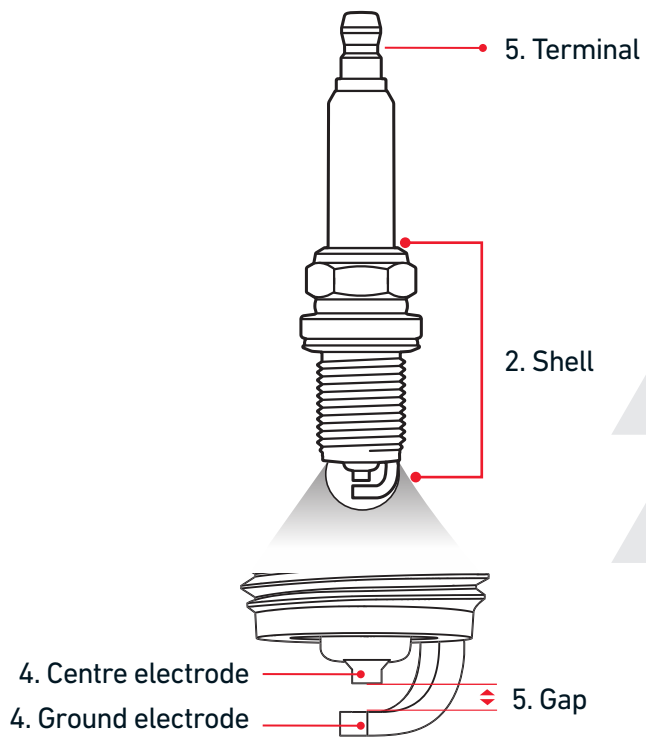
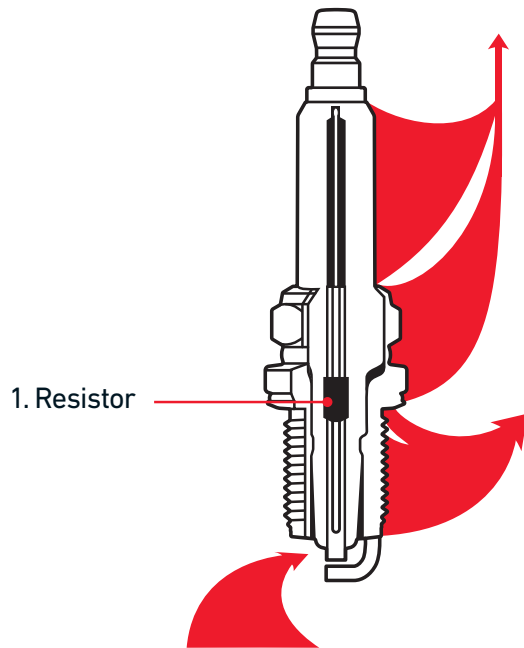

1. RESISTOR

Radio Frequency Interference is created by the ignition systems of internal combustion engines. During the microseconds of time that the spark is occurring at the spark plug gap, high frequency bursts of energy are created. These bursts of energy cause static and interference in radios, televisions, telephones and other sensitive electronic devices.

A **built-in resistor eliminates possible radio frequency interference (RFI)**. In this way guaranteeing a perfect ignition and trouble-free operation of all electronic on-board systems.

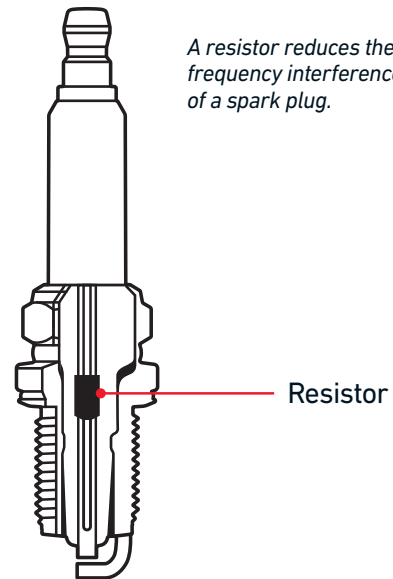

Your Champion benefit: perfect performance guaranteed

- FISS resistors are used in most of Champion plugs. Fired in Suppressor Seal (FISS) construction – stronger insulator – increases heat dissipation
- Optimum engine performance: no misfiring
- On Board Diagnostic compatibility
- Champion spark plugs are fitted with a **built-in resistor to eliminate radio frequency interference (RFI)**

2. SHELL

In developing plugs with car manufacturers, Champion always finds the best solution for each engine. Depending on the engine head and multiple other determining factors, different metal seats are developed and produced following the prescriptions of the OE engines.

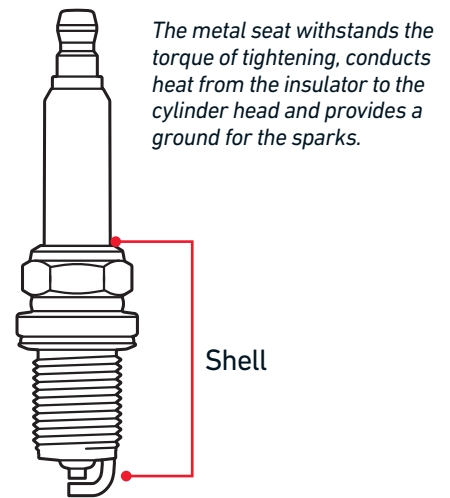

The **seat** prevents the combustion chamber from leaking using a compression gasket or taper interface seat. Each spark plug has a specific seat type which are not interchangeable. Spark plugs with a flat seat are used in engines designed for a gasket seal. Spark plugs with a tapered seat are used in engines designed for a tapered seal.

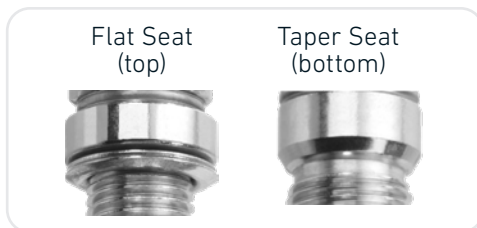

The **nut size indication** allows for tightening the plug. Usually it is a hexagonal nut – commonly hex – but it can also be bi-hex for specific applications in compact engines with longer spark plugs with small diameter.

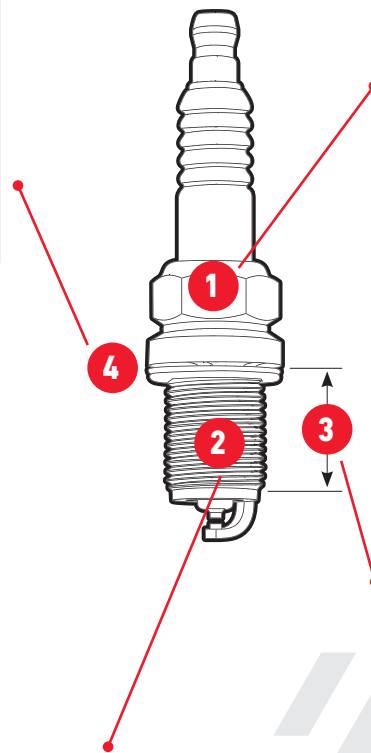
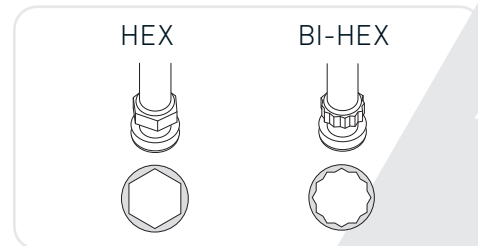

The **height of the threaded part** of the spark plug. Dimensions in millimeters.

SEAT	Thread Diameter	Tightening Torque Nm
GASKET	10 mm	10-15
	12 mm	20-25
	14 mm	25-30
TAPER	10 mm	10-15
	12 mm	15-20
	14 mm	15-20

The **thread dimensions and tightening torque**. See table for more specific details depending on whether the cylinder head is made of cast iron or aluminium, and the tightening torque in Nm to be applied.

Possible values of the numbers in the red circles can be found in the Product Code Table.

3. HEAT RANGE

The heat range indicates the **speed of which a plug can transfer heat from the combustion chamber to the engine head.**

The heat range of the plug is determined by the dimensions of the insulator and the seat. Spark plugs with short insulators are usually 'cooler' plugs, while 'hotter' plugs have a lengthened path to the metal seat. The thermally conductive metal core and the type of material of which the electrodes are made also influences the heat (see next chapter).

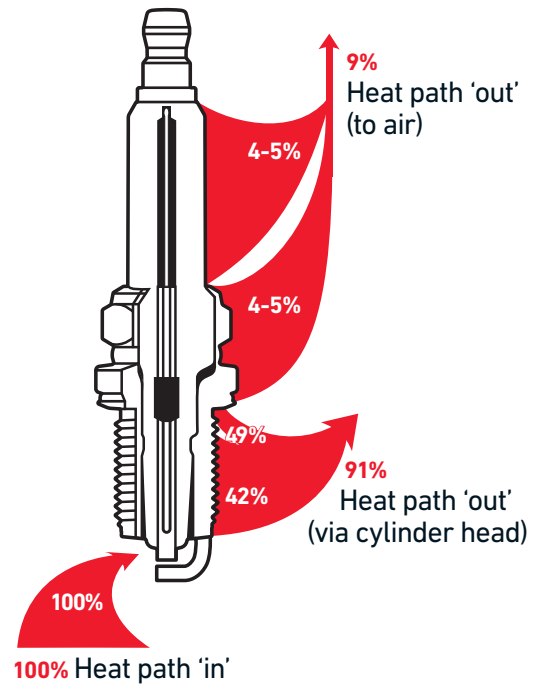

Cold spark plugs dissipate the heat **quicker** and thus the firing tip remains cooler (hence 'cold plug'). This avoids pre-ignition and makes them perfectly **suited for high compression, high performance engines**, that run hotter.

Hot spark plugs are specifically developed for **lower output engines**. The transfer of heat is slower (firing tip is hotter) and thus the plug retains more heat. By consequence, it burns off deposits **prevent fouling and assist cold starts**.

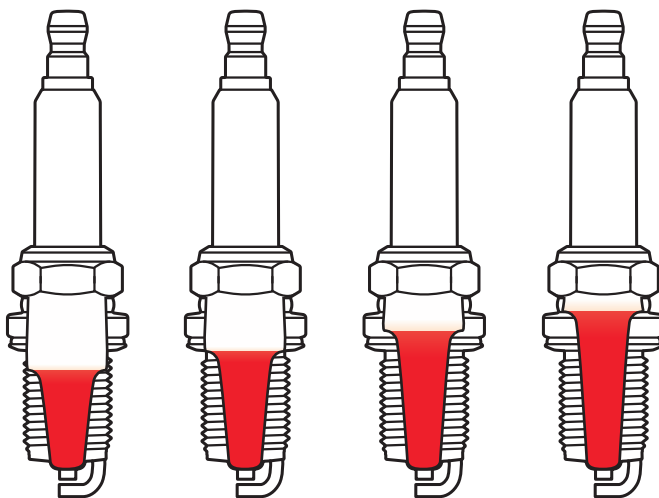

COLD → **HOT**

Cold spark plugs have a cooler firing tip because the heat is dissipated quicker.

4. ELECTRODES

The **centre electrode** is connected directly to the terminal. This can be made of (a combination of) copper, nickel-iron, chromium or noble metals like platinum, iridium. These are used because of their higher durability rather than their electric conductivity. Normally, it's the centre electrode that ejects the electrons, as it is the hottest of the two.

The **projection** of a spark plug is the distance from the end of the metal shell to the tip of the ceramic 'nose'.

The **ground electrode** (or side electrode) is mostly made from nickel-steel, in some cases with a copper core to increase heat conduction. This electrode is welded to the metal shell.

Champion spark plugs with a **Multi Ground Electrode** have a copper cored nickel centre electrode, coupled with 2-3-4 nickel ground electrodes. Multiple ground electrodes generally provide longer life. Because when the spark gap widens due to electric discharge wear, the spark can move to another closer ground electrode. Your Champion benefit: an increased service life upto 38,000 miles / 60,000 km.

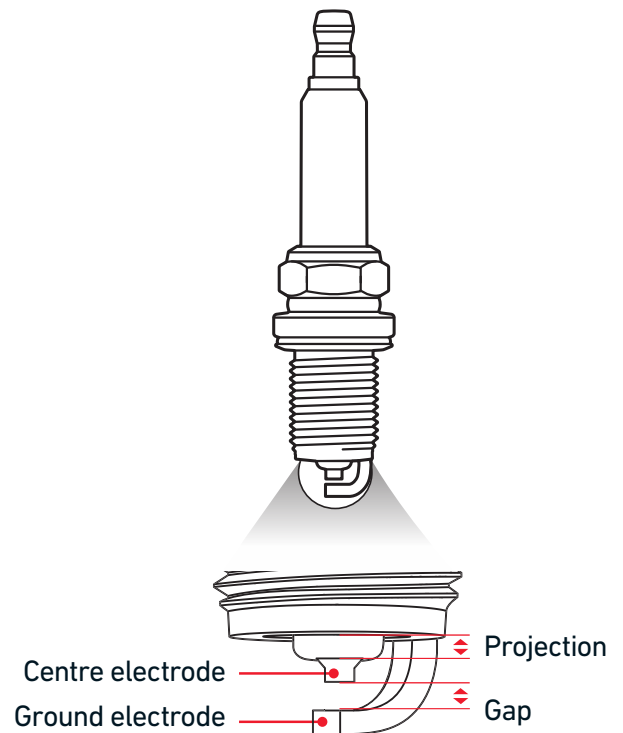

A multi ground spark plug has more than one ground electrode. Note the difference e.g. with spark plugs with a '1+2': these have 1 ground electrode and two (smaller) side electrodes. See image page 15.



Your Champion benefit: better performance and increased service life

Champion uses a wide variety of **proven technologies** and premium electrode materials like Platinum and Iridium, to make sure you get an increased service life and enhanced performance on every plug.

You find more info on all Champion technologies in **part III**.

5. TERMINAL AND GAP

A terminal is placed on top of each spark plug. Its role is to serve as a connector to the ignition system of the vehicle.

When developing plugs with car manufacturers, Champion always finds **the best solution for each engine**. Depending on the engine head and multiple other determining factors, **different terminals & gaps** are developed and produced following the prescriptions of the OE engines.

The terminal

There are 4 possible spark plug terminal configurations. See brochure part II.

The gap

The gap is the distance between the end of the centre electrode and the ground electrode. The distance is crucial to the spark plug performance as the slightest alteration could influence the proper functioning.

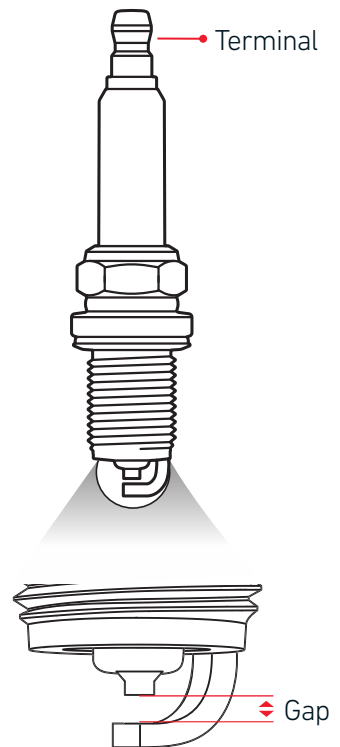

CHAMPION INNOVATION

Ribbed Core Nose Feature

In response to the OEM's requirement for a revolutionary spark plug to greatly improve the anti cold foul performance and cold start ability, Champion has developed the innovative **Ribbed Core Nose** spark plug.

It combines the **optimum ignitability** of a single ground electrode with the benefits of a multi-ground semi-surface design. And as semi-surface operation only occurs when the plug is fouled, **channelling is eliminated**.



Champion design



Competitor design



Your Champion benefit: Improved Cold Starting and Anti Fouling

- Multi electrode semi surface performance
- F.I.S.S. technology to meet all RFI and OBD requirements
- Double copper technology for extended life (60,000+ km / 40,000+ miles)
- Excellent performance across all grades of fuel

SEE WHAT OUR PACKAGING CAN TELL YOU

On each Champion spark plug packaging, a label indicates the **short product code** (e.g. OE220).

This short code corresponds with Champion's technical code. For instance, the short code OE220 corresponds to the **technical code** KEC4PYPBF-1



Short Code	→	Technical Code
OE219	→	KEC4PYPBF
OE220	→	KEC4PYPBF-1
OE246	→	KEC6WYPB-1

*Learn more about our part number structure in our brochure, part II.
Learn more about our technologies in our brochure, part III.*

SAME QUALITY, DIFFERENT PLUG

Champion plugs are developed **in close cooperation with the OE manufacturers**, in compliance with the most stringent requirements. In the **same OE facilities**, we also produce and optimize all our spark plugs for the aftermarket. So you can be sure that they will keep on **meeting or even exceeding the same standards**.

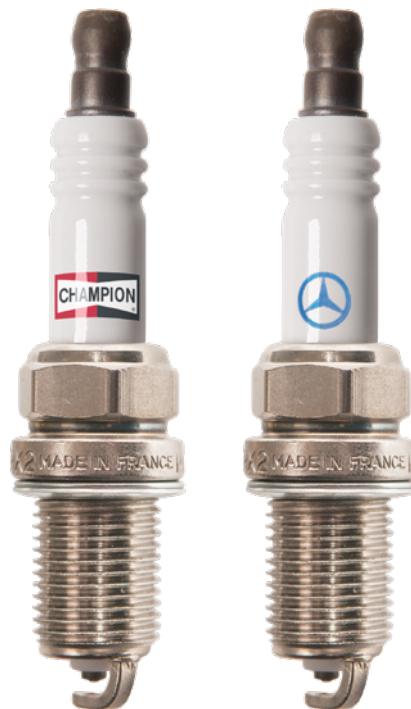

Champion plug

OEM plug

PROVEN TECHNOLOGY, PRODUCED IN WEST-EUROPE

- Improved **ignitability, performance and durability**
- Developed, tested and produced in our **global OE facilities**
- **European production** in our Chazelles-sur-Lyon (France) OE facility
- Meeting the **most stringent requirements** of OE manufacturers
- **Same quality standards** for OE manufacturers as for the aftermarket
- Including all **proven technologies** and industry-first **innovations**

Chazelles





LEADING VEHICLE PARC COVERAGE FOR SPARK PLUGS, AND INCREASING EVERY DAY

LEADING THE AFTERMARKET WITH OVER 95% COVERAGE FOR SPARK PLUGS

- For **automotive** and **non-automotive** applications
- OE plugs **directly available** for the aftermarket
- Including **technological innovations**
- Regular New Product Introductions **increasing the percentage of coverage continuously**