

HOW TO KEEP YOUR TECH SKILLS ON TREND?

Want to arm yourself with all the right tools & on trend information to keep up with the latest developments? Garage Gurus provides you with the most comprehensive program of support tools in the industry. Why? We believe that well-trained techs are at the heart of our rapidly changing vehicle repair industry. Join our technical community at www.fmgaragegurus.eu and find out everything you need to know through insightful video tutorials, tech tips, interviews, articles and courses. Ready for some fine-tuning?

THE GARAGE GURUS PROGRAM IS COMPRISED OF FOUR MAIN PILLARS, WHICH ALLOW CUSTOMERS TO RECEIVE SUPPORT IN A COMPREHENSIVE VARIETY OF WAYS:

ONSITE

Gurus Onsite: Garage Gurus has developed a range of professional lessons and courses that are hosted at the Garage Gurus' purpose-built, high-tech facility in the Netherlands, or at regional hubs. This enables workshop technicians to continually develop their career and keep up to date with the automotive market's increasingly complex technologies.

ON-CALL

Gurus On-Call: Technical specialists are available by phone to provide fast answers for product and diagnostic questions, whenever you need them. The team speaks six languages and covers 30 countries.

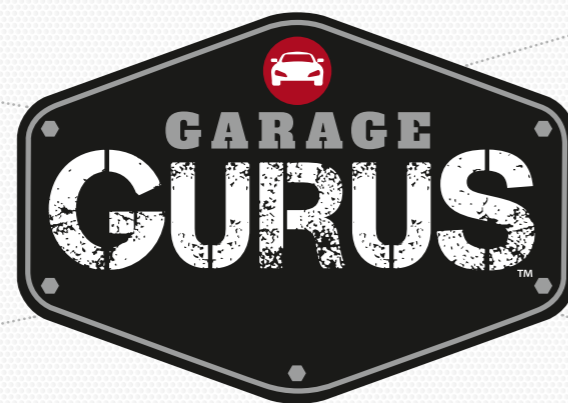

ON-THE-GO

Gurus On-the-Go: A fleet of technology-equipped vans that will tour workshops to provide interactive demonstrations and teach workshop personnel about the latest tools, part solutions and technologies. This service will initially launch in seven countries (France, Germany, Italy, Russia, Poland, Serbia, Romania) with additional countries to be added as the program develops.

ONLINE

Gurus Online: A technical training online platform that can be accessed 24/7 to help educate and develop knowledge of automotive systems, components and maintenance. The website includes interactive learning modules, technical tips and troubleshooting video guides. As well as access to Garage Gurus' technical team, it provides a platform where all users can communicate with each other in a forum to receive first hand advice.

FERODO®

INSTALLATION GUIDE

Mercedes E-Class 4Matic (w212) REAR BRAKES



BRAKE FLUID

BRAKE FLUID	
Product	DOT 4, Low viscosity
Capacity	1.0 litre
Maintenance intervals	Every 2 years

BRAKE FLUID DOT4 LOW VISCOSITY

FBX025	250 ml
FBX050	500 ml
FBX100	1 lt



FERODO PART NUMBERS, BRAKE PAD SET

FDB1526 (set)	Brake pad	(mm)
OE: 0004230230	Length	141
0044204420	Height	59.5
0074201020	Thickness	15.8
0074206720		
WVA: 23334		
23335		
Brake system: ATE		



To be fitted together with Ferodo disc DDF1672C

PARKING BRAKE

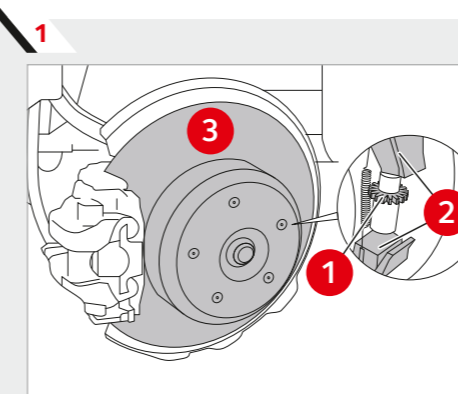

ADJUSTING WHEEL

ADJUSTMENT

- Place the vehicle on the vehicle lift.
- Remove the rear wheels.
- Rotate the adjusting wheel (Picture 1, n° 1) using a screwdriver until the brake shoes (Picture 1, n° 2) engage with the parking brake drum. This is indicated when the rear wheel or the brake disc (Picture 1, n° 3) can no longer be turned manually.
- Unscrew the adjusting wheel about 10 teeth.
- Check if the rear wheels or brake discs move smoothly.

For more information on Garage Gurus, to further your automotive education, or to join the growing community, visit www.fmgaragegurus.eu or send an e-mail to garage-gurus@fmmotorparts.eu

www.ferodo.com

The content contained in this article is for informational purposes only and should not be used in lieu of seeking professional advice from a certified technician or mechanic. We are not liable for any damages resulting from your reliance on this content.

Ferodo® is a registered trademark of Federal-Mogul LLC or one or more of its subsidiaries in one or more countries. **FEDERAL-MOGUL MOTORPARTS**

MERCEDES E-CLASS 4MATIC (W212) REAR BRAKES

BRAKE PADS

REMOVAL

- Disable the SBC brake system using a diagnostic tool.
- Place the vehicle on the vehicle lift and remove the rear wheels.
- Remove the brake pad retaining spring (Picture 2, n° 1).
- Undo the screws (Picture 2, n° 2) to release the caliper
- Remove the power cable of the brake lining contact sensor.
- Remove the caliper
- Remove the brake pads.

ASSEMBLY

- To assemble, follow the removal process in reverse order.
- Fill and bleed the brake circuit (if necessary).
- Enable the SBC brake system using a diagnostic tool.

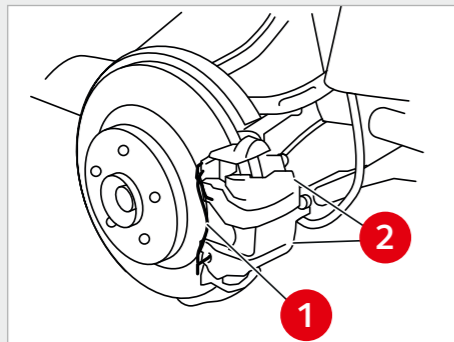

RETAINING SPRING, SCREWS

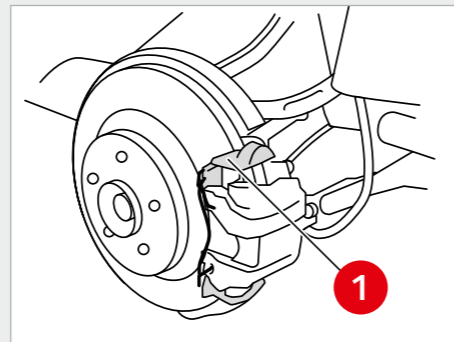

BRAKE CALIPER SUPPORT

HYDRAULIC CIRCUIT

FILLING AND BLEEDING

- Place the vehicle on the vehicle lift.
- Check if the clutch/brake fluid level is between the MIN and MAX marks.
- Remove the cap (Picture 4, n° 1) from the clutch/brake fluid reservoir and connect the appropriate kit (Picture 4, n° 2) to the reservoir.
- Remove the protective cap, connect the extraction device and open the bleed valve on the brake calipers.
- Slowly open the tap on the bleed kit and wait until all the air in the hydraulic system has come out.

Bleed sequence

1. Front left caliper
2. Front right caliper
3. Rear left caliper
4. Rear right caliper

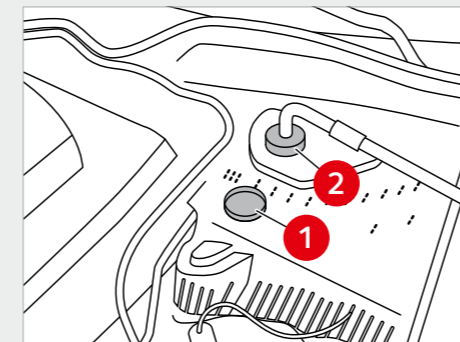

BLEED KIT ASSEMBLY

NOTE



- Carefully clean the cap and the entire top surface of the reservoir next to the opening to prevent impurities from entering the clutch/brake fluid reservoir, before unscrewing the cap.
- Once the bleeding operations have been completed, carry out a road test where at least one instance of ABS braking occurs.

BRAKE DISCS

REMOVAL

- Remove brake pads and caliper using the instructions in this document
- Remove the brake caliper support (Picture 3, n° 1) from the wheel support.
- Remove the rear disc from the wheel hub. Pay attention: Release the parking brake.

ASSEMBLY

- Clean contact surface of brake disc at wheel hub and remove corrosion. Unevenness on contact surface may result in distortion of brake disc.
- To assemble, follow the removal process in reverse order.
- Tighten the guide pin on the brake caliper support to a torque of 28 Nm.
- Fill and bleed the brake circuit (if necessary).
- Enable the SBC system using a diagnostic tool.

BRAKING SYSTEM NOTES AND PRECAUTIONS

Please use the Ferodo website for the correct brake components.

NOTE

The W212 is standard equipped with Sensotronic Brake Control (SBC). SBC is an electro-hydraulic brake system that allows braking pressure to be measured more precisely and rapidly, reducing the stopping distance particularly during emergency braking (Brake Assist System (BAS)). The SBC system can only be disabled using a suitable diagnostic tool.

OPERATING PRECAUTIONS

- Do not perform maintenance work on an SBC system without first disabling it.
- The automatic displacement of the brake piston can cause serious injury.
- Likewise serious injuries can be caused by high-pressure brake fluid leaks caused by braking pressures.
- Brake fluid is hygroscopic and needs to be replaced at regular intervals, avoiding use of fluid that is not within the specifications given in the table. Do not allow brake fluid to fall onto painted, rubber, plastic or mechanical parts.

